

Life Detection System Using L Band

J.ANOOHYA

Department of Electronics and Communication Engineering
Sree Visvesvaraya Institute of Technology and Science

Chowdarpally, Mahaboobnagar.

Jarubandeeanoohya487@gmail.com

Abstract: Now this era there were so many natural calamities and are not easily solvable. This will cause unusual happenings result in human lives being gone forever. In order to help those suffered under this bondage, a new revolutionary microwave life detection system which is used to locate human beings buried or trapped under earthquake rubble has been designed. This system operating at certain frequency (range defined) can remotely detect the breathing and heart beat signals of human beings buried under this rubble. By application of signal processing of these signals, the status of the person under trap can be easily determined. A new creative idea using microwaves called microwave life detection system which can be used to detect human subjects behind the barrier, wall or under earthquake rubble is discussed. In the past when victims were trapped under earthquake rubble, collapsed debris, there was a little chance they would be found. This was due to the fact that rescue techniques such as optical devices, acoustic devices or robotic systems were found limited applications for the detection of buried victims. With the help of microwave signals the life signs can be detected as it is able to sense the heart beat and breathing signals of human beings trapped under collapsed debris. A microwave life detection system operates at appropriate frequencies lies in X-band, L or S band.

Keywords: Life Detection System, L Band, microwave life-detection system, rescue robot.

1. INTRODUCTION

A new sensitive microwave life-detection system which uses dogs, optical devices and acoustic life detectors and can be used to locate human subjects buried under the rubble. But the dogs can detect the dead persons earthquake rubble or hidden behind various barriers and this occupies the precious time which can be utilized to be constructed. By advent of this system the world death detect alive victims. Also, the optical devices have a rate may decrease to a greater extent as a large percentage of limited number of degrees of freedom, require expert death occur due to earthquake. This system operating at operators and cannot be used in inaccessible areas. 1150 MHz or 450 MHz can detect the breathing and Acoustical detectors such as geophones are simple to use heartbeat signals of human subjects through earthquake but they require quiet working environments, a condition rubble or a construction barrier of about 10-ft thickness. difficult to reach especially in critical situations.

Previous methods for searching and rescuing human beings. The Rescue Robot can navigate deep into the rubble to victims buried under earthquake rubble or collapsed search for victims by the use of temperature sensor but they building debris were the utilization of dogs, or seismic or are unable to trap once they go out of range. Information optical devices. These devices are not effective if the location of buried person would be of great rubble or debris covering the human victims is thicker than value for the rescue personnel, since it would help to a few feet, especially for the case when the victims are reduced the time of operation and thus, help to save more completely trapped or too weak to respond to the signal lives. There is a need to construct a life detection system sent by the rescuers. The natural and manmade disaster which can detect buried victims under earthquake or such earthquakes, landslides, avalanches, have become building debris most efficiently and as possible in short common in the last decades due to these buildings tends to time. Such kinds of problems have been efficiently solved collapse on people. After most of these incidents, the considering continuous wave or ultra wideband radars common problem is that more number of lives could have which offer good localization and spatial accuracy.

been saved had the survivors been found and rescued earlier. This incident causes people to death to safeguard our technology is helpful. Hence there is a need to develop a comprehensive disaster management solution to tackle this problem. This proposed system is mounted on mobile flying unit such as a Quadrotor. It can be used survey an area to identify people who are buried under the rubble.

1.1 Need of Life Detection System over Conventional System

Existing ways to detect the human being under the earthquake rubble and collapsed buildings are utilization

In rescue mission and also in some surveillance operations there is not only the need of detect life signals but also the identification of people in a given area, to facilitate rescue team operations in case of emergencies. This task can be complied with through the wall surveillance techniques.

1.2 Introduction to Microwaves

Microwaves are electromagnetic waves with wavelengths ranging from as long as one meter to as short as one millimeter, or equivalently, with frequencies between 300 MHz (0.3 GHz) and 300 GHz. This broad definition

includes both UHF and EHF (millimeter waves), and had been proposed including the basic principle for the various sources use different boundaries. In all cases, operation of life detection system in 1991. A Low Power microwave includes the entire SHF band (3 to 30 GHz, or Hand-Held Microwave Device for the Detection of 10 to 1 cm) at minimum, with RF engineering often Trapped Human Personnel by W. S. Haddad in 1997. The putting the lower boundary at 1 GHz (30 cm), and the device, called the Rubble Rescue Radar (RRR) upper around 100 GHz (3mm). The microwave life incorporates Micropower Impulse Radar technology which detection system can works on different range of was developed at Lawrence Livermore National frequencies from L-band (2GHz) to X- band (10GHz). But Laboratory over the few years. X- band microwave is unable to penetrate deep into the

rubble. It can penetrate rubble up to 1.5 ft in the thickness In 2003 P. K. Banerjee and A. Sengupta proposed the (5 layers of bricks) .while L- band can penetrate the rubble basic block diagram for the clutter cancellation system. In of about 3 ft in thickness (10 layers of bricks) . Due to the 2004, there was a concept of three band radar system fact that lower frequency will be more capable of detecting proposed by M. Bimpas. The researcher put their effort to vital signs through very thick rubble, so frequency of an study the various effect various bands of microwave electromagnetic wave needs to be in the L-band or S-band signals and depending upon this, a system which detect range, For this reason, the a microwave life detection human being with ka-band with double sidebands have system which operates on the L-band frequency. This been proposed, in 2006. It states that a short wavelength of system is supposed to quite efficient to trap the breathing ka-band increases the sensitivity of antenna which will and heartbeat signals of victims who are completely detect the small body vibration. A paper on „An X-band

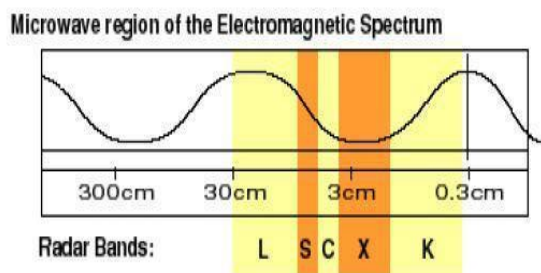

Fig 1.1. Microwave region of electromagnetic spectrum

2. LITERATURE SURVEY area on foot to

2.1 History

Images of events causing damage in which people have been trapped or buried under rubble serve as constant reminders of the vulnerability of the places where we live and work. To conduct rapid rescue operations, emergency forces all over the world need timely information on the exact position of people trapped or buried under rubble, information on the risk of collapse of debris and standardization intervention procedures as well as information on the state of the victims' health. Collapse of man-made structures, such as buildings and bridges, occur with varying frequency across the world. In such a case, survived human beings are often trapped in the cavities created by collapsed building material. The concept of microwave life detection system was emerged with the development in the systems for rescue operation. Initial dogs were used to detect presence of human then acoustic detectors and robot radar come into existence. But these systems are having major drawbacks. The history of "Revolutionary System to detect Human Being Buried Under the Rubble" starts with K. M. Chen who brings out the concept of detection of buried victims using microwave beam in 1985. After the detailed study of microwave signals and Doppler's effect, Ku Mem chen

microwave life detection system" has been presented by Huey Ru in 2007. In this paper author present the idea of detecting human being located behind the wall using a microwave signal. The phase change of a reflected microwave signal will provide the precious information about the buried victim's heartbeat as well as breathing. A rescue radar system is proposed by M. Donelli in 2011. In radar system a SAW oscillator is used to generate 10GHz frequency signals. While receiving through patch antenna the signal is process by the ICA (Independent Component Algorithm)[9].

2.2 Existing Technology

In manual surveying rescue personnel manually scout the area to identify the location of survivors. This surveying concept is not as efficient and also time consuming is high there are several methods. There are several ways to prevent avalanches and lessen their power and destruction. They are employed in areas where avalanches pose a significant threat to people the threats not only for avalanche but also many disaster like earthquake, landslide this manual survey concept is not efficient. Next concept is sniffer dogs which are used by rescue personnel to aid them in their search and rescue operations but the cost is high for training the dog but this concept is not effective. These concept is time consuming. Next concept is optical devices such as a camera are also used to identify survivors. These optical devices are lowered down into the rubble to look for survivors. This method is also time consuming and cannot be used for all location and these are time consuming. Penetration power is not high so this concept can only have a penetration of less than 1.2 feet. The next concept is acoustical detectors such as geophones are simple to use but they require quiet working environments, which is impossible to achieve in monsoon season so this concept also not good. Next concept is breath sensor it is used to detect the metabolites but there is hazardous gas release during breathing and sweating so this concept is not as effective but this technique is not tested.

2.3 Proposed Technology Using L-Band Life Detection System

The entire Microwave Life Detection system is mounted on an MFU (Mobile Flying Unit) such as a Quadrotor. The MFU is either controlled by rescue personnel from a remote location or it can be made completely autonomous to survey a demarcated area. The survivors are detected by using a Microwave L-Band life detection system. Once the unit detects a survivor, it immediately sends the coordinates of the to the base station. Hence, the rescue personnel can easily approach and clear the areas with survivors. This device also has position sensors to find the people who were buried under the rubble. The microwave life detection system can work on different range of frequencies from L-band (2GHz) to X- band (10GHz). But X- band microwave is unable to penetrate deep into the rubble. It can penetrate rubble up to 1.5 ft in the thickness (5 layers of bricks) while L- band can penetrate the rubble of about 3 ft in thickness (10 layers of bricks). For this reason, the microwave life detection system operates on the L-band frequency. This system is efficient in trapping the breathing and heartbeat signals of victims who are completely trapped and too weak to respond. The l band life detection system has greater penetration power than other bands . This L-band comes under visible spectrum. Here phase locked oscillator which is used as a frequency controller the phase locked oscillator which is used at frequency of 1150mhz, directional coupler used for distribution of power which having a range of 10db and 3db,circulator used for transforming microwave to next port it is a 3 or 4 port device, RF switch used to route high frequency, digitally controlled phase shifter used to control microwave signal, fixed attenuator used for impedance matching, RF amplifier used for amplifying the signals, digitally controlled attenuator used to control microwave signal, mixer, RF pre amplifier used for the connection done directly to the mixer, detector for detecting the signals, LF amplifiers and filter for reduction of noise in the signal, microprocessor based control system for which about AT89C51microcontroller is used, for display laptop is used[1].

3. LIFE DETECTION SYSTEM USING L BAND

3.1 Block Diagram of Proposed System

The microwave life detection system has four major components as shown in fig.3.1. They are a microwave circuit which generates, amplifies and distributes microwave signals to different microwave components. A dual antenna system, which consists of two antennas, energized sequentially. A microwave controlled clutter cancellation system, which creates an optimal signal to cancel the clutter from the rubble.

3.1.1 Phase Locked Oscillator

A phase-shift oscillator is a simple electronic oscillator. It contains an inverting amplifier, and a feedback filter which 'shifts' the phase of the amplifier output by 180 degrees at a specific oscillation frequency.

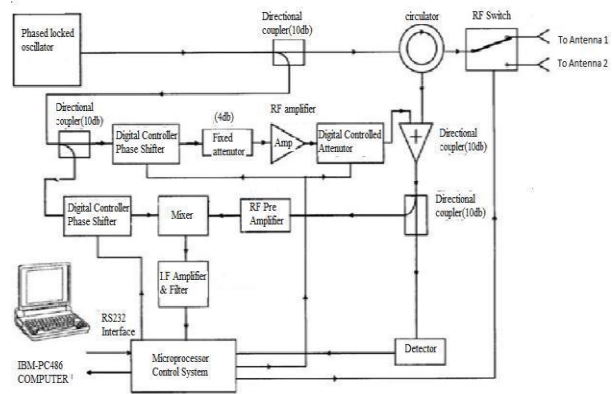

Fig 3.1 Schematic diagram of the 1150-MHz microwave life-detection system

The filter produces a phase shift that increases with frequency. It must have a maximum phase shift of considerably greater than 180° at high frequencies, so that the phase shift at the desired oscillation frequency is 180°. Here the phase locked oscillator generates a very stable electromagnetic wave say 1150 MHz with output power say 400mW.

3.1.2 Directional Coupler

Directional couplers are four-port circuits where one port is isolated from the input port. Directional couplers are passive reciprocal networks, which you can read more about on our page on basic network theory. All four ports are (ideally) matched, and the circuit is (ideally) lossless. A directional coupler has four ports, where one is regarded as the input, one is regarded as the "through" port (where most of the incident signal exits), one is regarded as the coupled port (where a fixed fraction of the input signal appears, usually expressed in dB), and an isolated port, which is usually terminated. If the signal is reversed so that it enter the "though" port, most of it exits the "input" port, but the coupled port is now the port that was previously regarded as the "isolated port". The coupled port is a function of which port is the incident port. Waveguide couplers couple in the forward direction (forward-wave couplers); a signal incident on port 1 will couple to port 3 (port 4 is isolated). Micro strip or strip line coupler are "backward wave" couplers. The micro wave life detection system uses four directional couplers; two 3dB, one 6dB and one 10 dB directional coupler.

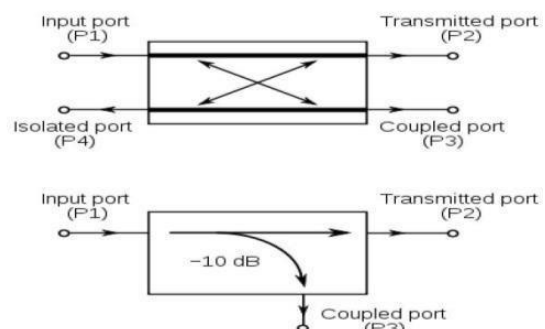

Fig 3.2 Two common symbols for directional couplers

3.1.3 Circulator

A circulator is a ferrite device (ferrite is a class of converter materials with strange magnetic properties) with usually three ports. The beautiful thing about circulators is that they are non-reciprocal. That is, energy into port 1 predominantly exits port 2, energy into port 2 exits port 3, and energy into port 3 exits port 1. In a reciprocal device the initial clutter signal as a reference. The microcontroller sets 1 dB as a minimum attenuation in the attenuator and would occur to energy flowing the opposite direction, tries all phase settings from 00 to 3600 in the phase shifter from port 2 to port 1. The selection of ports is arbitrary, and repeats the procedure until it gets the minimum DC and circulators can be made to "circulate" either clockwise output of detector and sets attenuator and phase shifter (CW) or counter clockwise (CCW). A circulator is control switches accordingly Maximum cancellation sometimes called a "duplexer", meaning that is duplexes depends on the resolution of attenuator and phase shifter two signals into one channel (e.g. transmit and receive into and properties of rubble like constituents of the barrier, an antenna). In microwave life detection system there are shape, size, its orientation with respect to the direction of two antennas. The antenna can perform two functions incident radio wave etc. simultaneously with the help of circulator, which separates the radiating EM wave from the received EM wave.

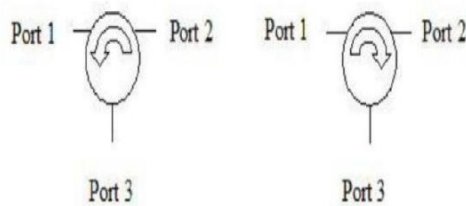

Fig3.3 CCW and CW circulators

3.1.4 Antenna System

The dual antenna system has two antennas, which are energized sequentially by an electronically controlled microwave single-pole double-throw (SPDT) switch. The SPDT switch turns on and off at a frequency of 100 Hz which is much higher than the frequency range of the breathing and heartbeat signals between 0.2 Hz and 3 Hz. Thus, we can consider that the two antennas essentially sample their respective objects at the same time. In this dual-antenna system, the two antenna channels are completely independent. Each antenna acts separately. We have designed and constructed three types of antennas for the microwave life-detection system. They are: 1) the reflector antenna; 2) the patch antenna; and 3) the probe antenna. Each antenna simultaneously acts as the radiating element and the receiving element. It radiates EM wave through the earthquake rubble to reach the trapped human subjects and at the same time it receives the reflected EM wave from the rubble and the human subjects

3.1.5 Clutter Canceller System

In any remote sensing instrument the clutter caused by undesirable objects surrounding the detectable subject must be cancel to the optimum level. The clutter canceller forms the heart of life detection system. It consists of Programmable Phase Shifters, Programmable Attenuator, a RF amplifier based control unit.

3.1.5.1 Canceller operation

The clutter signal is passed through a detector as shown in fig.3.5 which outputs a DC voltage of few tens mV. Then

it is amplified by an operational amplifier and fed to A/D

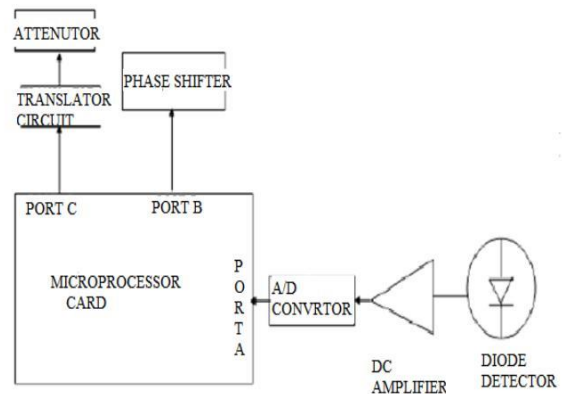

Fig3.5 Clutter cancellation circuit

4. WORKING OF THE SYSTEM

4.1 Operation of System

The circuit diagram of the microwave life-detection system is shown in Fig.3.1. A phase-locked oscillator generates a very stable EM wave at 1150 MHz with an output power of 400mW (25.6 dBm). This wave is fed through a 10-dB directional coupler and a circulator before reaching a radio-frequency (RF) switch, which energized the dual antenna system sequentially. The 10-dB directional coupler branches out one-tenth of the wave (40 mW) which is then divided equally by a 3-dB directional coupler. One output of the 3-dB directional coupler (20 mW) drives the clutter cancellation circuit and the other output (20 mW) serves as a local reference signal for the double-balanced mixer. The wave radiated by an antenna penetrates the earthquake rubble to reach a buried human subject. The reflected wave received by the same antenna consists of a large reflected wave (clutter) from the rubble and a small reflected wave from the subject's body. The large clutter from the rubble can be cancelled by a clutter canceling signal. However, the small reflected wave from the subject's body cannot be cancelled by a pure sinusoidal, canceling signal because it is modulated by the subject's motions. The dual-antenna system has two antennas, which are energized sequentially by an electronic switch.

It will act as transmitter as well as receiver according to its programming [6]. The clutter cancellation circuit consists of a digitally controlled phase-shifter (0–3600), a fixed attenuator (4 dB), a RF amplifier (20 dB), and a digitally controlled attenuator (0–30 dB). The output of the clutter cancellation circuit is automatically adjusted to be of equal amplitude and opposite phase as that of the clutter from the rubble. Thus, when the output of the clutter cancellation circuit is mixed with the received signal from the antenna, via the circulator, in a 3-dB directional coupler, the large clutter from the rubble is completely canceled, and the output of the 3-dB directional coupler consists only of the small reflected wave from the subject body. This output of the 3-dB directional coupler is passed through a 6-dB directional coupler. The 1/4th of this output is amplified by a RF preamplifier (30 dB) and then mixed with a local reference signal in a double balanced mixer. The other 3/4th of the output is detected by a microwave detector to provide a dc voltage, which serves as the indicator for the degree of the clutter cancellation. At the double-balanced mixer, the amplified signal of the reflected wave from the subject's body is mixed with a local reference signal. The phase of the local reference signal is controlled by another digitally controlled phase-shifter (0–1800) for an optimal output from the mixer. The output of the mixer consists of the breathing and heartbeat signals of the human subject plus unavoidable noise. This output is fed through a low-frequency (LF) amplifier (20–40dB) and a bandpass filter (0.1–4 Hz) before being displayed on the monitor of a laptop computer. The function of a digitally controlled phase-shifter (0–1800) installed in front of the local reference signal port of the double balanced mixer to control the phase of the local reference signal for the purpose of increasing the system sensitivity. The local reference signal is assumed to be $AL \cos(\omega t + \theta_L)$ where AL is the amplitude and θ_L are the phase, respectively. While the other input to the mixer, the reflected signal from the human subject, is assumed to be $A_r \cos(\omega t + \theta_r + \phi(t))$, where A_r is the amplitude and $\phi(t)$ the phase, respectively, and $(\theta_r + \phi(t))$ is the modulated phase due to the body movement of the human subject. ω is the angular frequency and t is the time. When these two inputs are mixed in the double-balanced mixer, the output of the mixer will be $AL A_r \cos(\theta_L - \theta_r - \phi(t))$. From this expression of the mixer output, it is easy to see that if $\theta_L - \theta_r - \phi(t) = (n + \frac{1}{2})\pi$, $n = 0, 1, 2, \dots$ the system has a maximum sensitivity and if $\theta_L - \theta_r - \phi(t) = n\pi$, $n = 0, 1, 2, \dots$ the system has a minimum sensitivity because $(U/U(-\phi(t))) \cos(\theta_L - \theta_r - \phi(t)) = \sin(\theta_L - \theta_r - \phi(t))$. $\phi(t)$ is usually a small phase angle perturbation created by the body movement of the human subject. θ_r is the constant phase associated with the reflected signal from the human subject and it cannot be changed. θ_L is the phase of the local reference signal and it can be controlled by the digitally controlled phase-shifter (0–180). In the operation, the phase shifter will automatically shift θ_L in such a way that $\theta_L - \theta_r$ is nearly $(n + \frac{1}{2})\pi$ to attain maximum system sensitivity. The microprocessors control

4.4 Performance Analysis

A several experiments are performed with the life detection system. Various layers of bricks were used to simulate the thickness W of rubble or barrier and the distance between the victim and the barrier of rubble D was variable parameter for the experiment. In the graphs, the heartbeat signal (when the human subject holding his

circuit and the LF amplifier/ filter circuit of the microwave life-detection system are described in detail elsewhere[5].

4.2 Modulation

The microwave beam incident into the rubble gets phase modulated due to body vibration. The phase modulation is occurs according to the Doppler Shift. The use of Doppler radar was demonstrated for detection of respiratory rate and heart rate using commercially available waveguide X-band Doppler transceivers.

4.2.1 Doppler Shift Effect

When a source generating waves moves relative to an observer, or when an observer moves relative to a source, there is an apparent shift in frequency. If the distance between the observer and the source is increasing, the frequency apparently decreases, whereas the frequency apparently increases if the distance between the observer and the source is decreasing. This relationship is called Doppler Effect (or Doppler Shift) after Austrian Physicist Christian Johann Doppler (1803-1853). By the Doppler Effect, microwave beam reflected from a moving surface undergoes a frequency shift proportional to the surface velocity. If the surface is moving periodically, such as the chest surface of person due to breathing, this can be termed as a phase shift proportional to the surface displacement. If the movement is small compared to the wavelength, the system will mixed received signal with transmitted signal which gives output proportional to the body oscillation of human subject concept. Internal body reflections are greatly attenuated and will not be considered here. We assume that a continuous wave (CW) radar system transmits a signal of frequency f . The actual working of Doppler shift starts with reflected beam from a target at a distance d_0 , with a time-varying displacement given by $x(t)$. Major limitations of the single channel configuration is detection sensitivity to target position due to a periodic phase relationship between the received signal and local oscillator, resulting in "optimum" and "null" extreme target positions.

4.3 Demodulation

At the double balanced mixer, the amplified signal of the reflected wave from the person's body is mixed with the local reference signal. The phase of the local reference signal is controlled by another digitally controlled phase shifter 2 for an optimal output from the mixer. The output of the mixer consists of the breathing and heartbeat signals of the human plus some avoidable noise. This output is fed through a low frequency amplifier and a band pass filter (0.4 Hz) before displayed on the monitor. The function of the digitally controlled phase shifter 2 is to control the phase of the local reference signal for the purpose of increasing the system sensitivity. The output of the mixer consists of the breathing and heartbeat signals of the human subject plus unavoidable noise. This output is fed through a low-frequency (LF) amplifier (20–40 dB) and a bandpass filter (0.1–4 Hz) before being displayed on the monitor of a laptop computer.

breath), the breathing signal, and the background noise were include. Firstly, the heartbeat and breathing signals were detected for each position. When the thickness of this wall increases to eight layers (about 90 cm), the performance of the L band life-detecting system became marginal. For the distance $D = 16$ m, the system was marginal. Fig.4.1 to Fig4.4 is the Fast Fourier Transform (FFT) of the time-domain signal, which shows the

frequency components of the time domain signal. Figures show the same result performed on the same distance D for the different thickness as shown respectively.

The frequency domain FFT results show the peaks of heartbeat signal (0.8 Hz to 2.5 Hz) and breathing signal (0.2 Hz to 0.5 Hz). Other small peaks are probably due to noises or the second harmonic of the breathing signal. When all these result were compared it is found that the amplitude of the breathing signal is becoming smaller with the increase of the wall's thickness. The heartbeat signal peak also decreases with the increase of the wall's thickness. Fig.4.4 show the FFT results behind the same wall. The distance (D) is 4m, 8m and 12m accordingly. It can be concluded from the result, thickness affects breathing signal whereas distance D affects heartbeats signals. The L band system performs better enough for remotely buried victims signals. Our experiments prove that a buried victim can be efficiently detected using lower band frequency. The possible shortcoming of the system is the effect of background noise created by the environment and operators. Interference caused by background random noise created by the environment and operator can produce spurious peaks around 0.7, 0.3 and 1.3 Hz and may cause misjudgment in the rescue effort. To avoid such interference new system was developed in 2008 by Chi-Wei Wu who uses EM pulse instead of continuous wave as a radiation source of microwave life detection system. In this life detection system, the amplitude and sign of echo from particular target will depend on the phase of the echo signal relative to that of local oscillator signal. Since wavelength of EM wave is is very short, approximately 3 cm for a carrier frequency of 10 GHz, the phase of the echo can change greatly if the target moves even slightly. Based on this physical behavior the components of pulse radar system can be rearranged to work as a life detection system. This system can operates at 2-G Hz and it will be used remotely to detect the breathing and heartbeat signals of alive subjects through rubble or some other barriers about 3ft in thickness. The microprocessor-based automatic clutter- canceling increases the efficiency of system. The clutter canceller uses an adjustable attenuator and phase shifter to cancel the transmitting power leakage from the circulator and background reflection clutter to enhance the detecting sensitivity of the weak vital signals.

4.4.1 Advantages

- Remote life sensing could be a powerful tool in applications where it is not desirable to disturb a subject's physiological and/or emotional state during detection or in other situations where access to the subject is limited.

Fig.4.1 Frequency spectrum of background noise

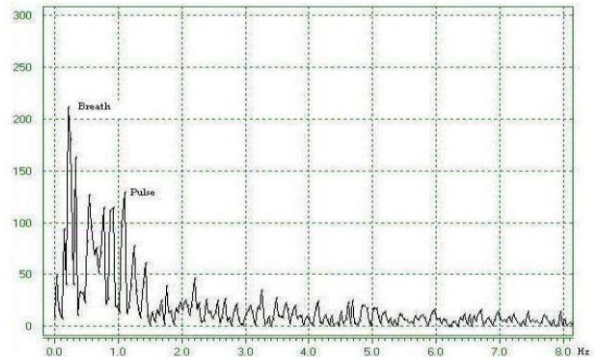

Fig.4.2 Frequency spectrum of breathing and heartbeat, $D=1\text{m}$, $W=24\text{cm}$

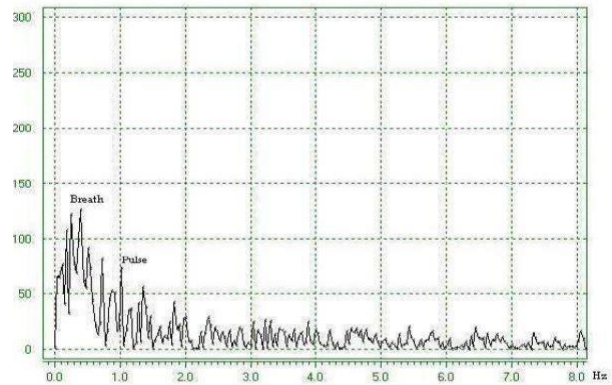

Fig.4.3 Frequency spectrum of breathing and heartbeat, $D=8\text{m}$, $W=24\text{cm}$

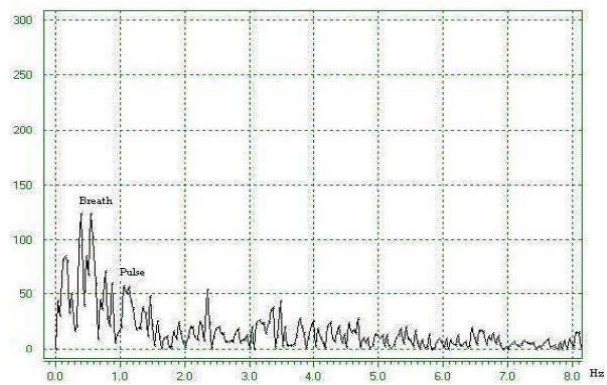

Fig.4.4 Frequency spectrum of breathing and heartbeat, $D=12\text{m}$, $W=24\text{cm}$

- The frequency 2.45 GHz i.e. L-band frequency and this is free for use by commercial applications, so we accept a minimum interference with other devices during our tests.
- No need to use heart beat and the breathing sensor. Our interest in just to observe the minute movement of the victim.

4.4.2 Disadvantages

- Project is expensive but once it is implemented the expenses can be reduced.
- The L-band frequency is unable to penetrate more metal like structure but it can penetrate over 10 layers of bricks.
- The involvement of clutter signal may destroy the vital information of life signs. But if the proper demodulation is used one can receive the vital signs efficiently.

4.5 System Sensitivity

The function of a digitally controlled phase-shifter ($0-180^\circ$) installed in front of the local reference signal port of the double balanced mixer to control the phase of the local reference signal for the purpose of increasing the system sensitivity. While the other input to the mixer, reflected signal from the human subject, is assumed to be $AR \cos(\omega t + \theta_E + \Delta\theta(t))$ where AR and θ_E are the amplitude and the phase, respectively, and $\Delta\theta(t)$ is the phase modulation due to the body movement of the human subject. " ω " is the angular frequency and " t " is the time. When these two inputs are mixed in the double-balanced mixer, the output of the mixer will be $ALAR \cos(\theta_L - \theta_E - \Delta\theta(t))$. From this expression of the mixer output, it is easy to see that if $(\theta_L - \theta_E) = (n + 1/2)\pi, n = 0, 1, 2, \dots$ the system has a maximum sensitivity; and if $(\theta_L - \theta_E) = \pm n\pi, n = 0, 1, 2, \dots$ the system has a minimum sensitivity (2), $\Delta\theta(t)$ is usually a small phase angle perturbation created by the body movement of the human subject. θ_E is the constant phase associated with the reflected signal from the human subject and it cannot be changed. θ_L is the phase of the local reference signal and it can be controlled by the digitally controlled phase shifter ($0-180^\circ$). In the operation, the phase-shifter will automatically shift θ_L in such a way that $(\theta_L - \theta_E)$ is nearly $(n + 1/2)\pi$ to attain a maximum system [6].

5. CONCLUSIONS

5.1 Instances of Application of Microwave L-Band Technology

The L-band (1452-1492 MHz) is currently allocated for use by terrestrial and satellite digital audio broadcasting (DAB) services in most European countries. In Africa,

CRASA, which groups together the 14 Southern African Development Community (SADC) countries, highlighted in its latest Frequency Allocation Plan (FAP) its framework for the harmonization across SADC on the use of the radio frequency spectrum, that: "T-DAB in the 1452-1492 MHz to be reconsidered: whereas this band was used for testing of T-DAB it was felt by the majority that this allocation is no longer required. The use of this band in the future should be further investigated and clarified."

5.2 Conclusions

A new sensitive life-detection system using microwave radiation for locating human subjects buried under earthquake rubble or hidden behind various barriers has been constructed. This system operating at 1150 or 450 MHz can detect the breathing and heartbeat signals of human subjects through an earthquake rubble or a construction barrier of about 10-ft thickness. The location of the person under the rubble can be known by calculating the time lapse between the sending time, T_s and receiving time, T_r . Since it will not be possible to continuously watch the system under critical situations, an alarm system has been set, so that whenever the laptop computer system processes the received signal and identifies that there is a human being, the alarm sound starts. The possible shortcoming of this system is the effects of the background noise created by the environment and operators. A sophisticated signal processing scheme may further improve the system performance.

5.3 Future Scope

In future, depending upon the developing such technology, if we can enhance the system so that it will be able to detect number of victims buried under the respective rubble. Then rescuer will prefer area with more number of victims. Eventually, our system can save more lives.

REFERENCES

- [1] Bhalchandra B. Godbole, International Journal of Innovative Research in Advanced Engineering (IJIRAE) ISSN: 2349-2163 Volume 1 Issue 11 (November 2014).
- [2] Miss Zade Gauri N, International Journal of Advanced Engineering Research and Studies, A Modern Microwave Life Detection System For Human Being Buried Under Rubble E-ISSN 2249 – 8974.
- [3] E. Parthiban And S. Benon, Microwave Life Detection System, ISSN: 2321-8045 Volume-1, Issue-5, 22nd August-2013.
- [4] Arvind. A., Uthira Mohan, Microwave L Band Life Detection System, SSRG International Journal of Electronics and Communication Engineering (SSRG-IJECE) – volume 1 issue 6 August 2014.
- [5] K. M. Chen, Y. Huang, A. Norman, and J. Zhang, "Microwave life-detection system for detecting human subjects through barriers," in Proc. Progress in Electromagnetic Research Symp., Hong Kong.
- [6] www.ieee.org.in.
- [7] www.wikipedia.com
- [8] www.sciencedirect.com
- [9] www.google.com